

**#230059 KICKOUT OPTION KIT (POWER APPLIANCE TRUCKS)
Assembly Instructions and Parts Manual**

Attention: To insure proper use of your Wesco Kickout, read and follow these instructions before using.

Specifications

The Wesco Kickout Option is designed exclusively for use with Wesco power appliance trucks. The Kickout Option Kit converts the appliance truck to a four-wheel truck for ease of handling with heavy loads.



These products are manufactured by:

WESCO Industrial Products, Inc.

P.O. Box 47

Lansdale, PA 19446

Tel: 215-699-7031 FAX: 215-699-3836

Contact the factory if you have problems after reading these instructions, or for parts information and parts ordering.

Unpacking

When unpacking your Kickout Option Kit, check carefully for shipping damage and missing parts. If damage has occurred or any parts are missing, file a claim with the delivering carrier within 24 hours and notify the dealer from whom the set was purchased.

General Safety Information

Warning: The Wesco Kickout is intended for specific functions. Please adhere to the following instructions to insure proper use.

- (1) Maximum capacity: limited to that of the truck on which they are installed.
- (2) The Wesco Kickout is designed exclusively for use with Wesco power appliance trucks to assist in the transport of heavy loads.
- (3) Do not install or attempt to install the Kickout option on any trucks other than Wesco power appliance trucks.
- (4) Periodically, inspect the Kickout assembly for damage, wear, and loose hardware. If required, remove from service and repair.
- (5) Use only genuine Wesco replacement parts when servicing.

For Warranty Repairs

- (1) If the unit does not work properly, contact your dealer or the factory (215-699-7031) for units less than ninety days old.

For Non-Warranty Service:

- (1) For units older than ninety days, repairs can be made easily on site with factory supplied parts. **NOTE:** *Do not send units to the factory for service without obtaining a "returned goods authorization number" from the customer service department. We will not be responsible for goods returned without proper authorization.*

To Purchase Parts:

- (1) A complete parts listing appears on the other side of this instruction sheet. Refer to the assembly drawing for item numbers. Note: the illustration depicts the mounting of a Kickout Option Kit to a power appliance truck. **To order parts,** contact the factory at the phone or fax numbers shown on this page of the instruction manual. **Ask for the Customer Service**

Depart-

Assembly

- 1) Assemble (4) upper reinforcement plates, one inside (item 1) and one outside (item 3) on each side of frame. Align center of 1/2" dia center holes before tightening 1/4-20 screws (item 10) and locknuts (item 22).
- 2) Assemble (2) lower reinforcement plates (item 1), on inside of each side of frame. Align center of 9/16" dia holes with frame before tightening 1/4-20 screws (item 10) and locknuts (item 22).
- 3) Assemble kickout (item 5) to frame with kickout crossbar away from frame and top pivot hole aligned with upper reinforcement plate. secure with 1/2 dia shoulder screw (item 11, washer (item 16), washer (item 24), nut (item 15)
- 4) With kickout in the open position, spread supports (item 8) to clear frame and insert ends into lower reinforcement plates. Secure with washer (item 9) and cotter pin (item 17) on inside of frame. Cover ends of rods with cap (item 13).
- 5) Test operation by lowering kickout (pull up supports by black knobs on outside ends), lock kick out to

Parts List

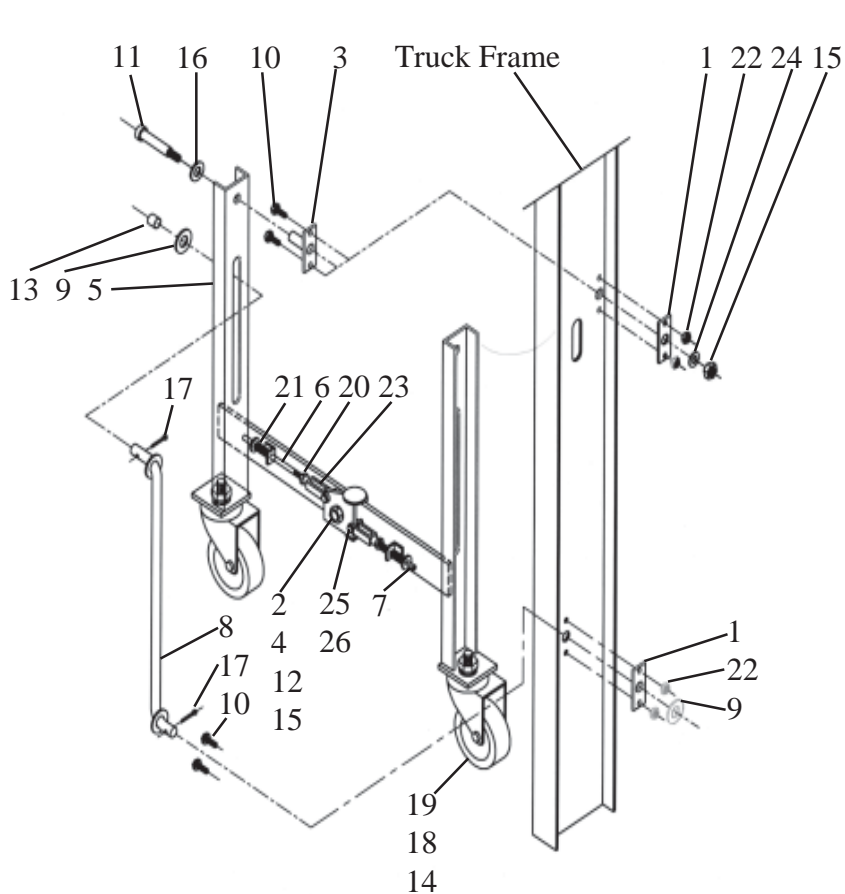

ITEM	PART NO.	DESCRIPTION	QTY
1	050522	Support: Crossbar	4
2	054515	Pad: Safety	1
3	055608	Pivot: Kickout	2
4	055611	Lever; Release	1
5	055612	Kickout	1
6	055613	Lockrod R.H.	1
7	055614	Lockrod L.H.	1
8	055615	Support	2
9	100051	Washer: Flat 5/8"	4
10	100158	HHCS: 1/4-20 x 3/4"	8
11	101104	Shld. Scr. 1/2" x 2-1/4"	2
12	101105	Shld Scr. 1/2" X 3/4"	1
13	108137	Cap: Black	2
14	108176	Nut: Jam 1/2-13	2
15	108180	Nut: Nylock 3/8-16	3
16	108200	Washer: Flat 1/2"	2
17	108219	Pin: Cotter 5/32" x 1"	4
18	108228	Washer: Lock 1/2"	2
19	108457	Caster	2
20	108854	Nut: Hex 1/4-28	2
21	108924	Spring	2
22	108929	Nut: Nylock 1/4-20	8
23	108950	Clevis: Rod End	2
24	109634	Washer: Flat 3/8"	3
25	108105	Pin: Clevis	2
26	108428	Pin: Cotter	2

LIMITED WARRANTY

WESCO Industrial Products, Inc. (WESCO) warrants to the purchaser of this product for a period of ninety (90) days from the date of purchase that this product shall be free of defects in material and/or workmanship, as follows:

1. WESCO will supply, at no charge, new or rebuilt replacements for any part that fails through a defect in material and/or workmanship during the warranty period. To obtain warranty service, you must deliver the product prepaid, to the WESCO factory.

2. This warranty does not cover any product or product part which has been subject to accident, misuse, abuse or negligence. WESCO shall only be liable under this warranty if the product is used the the manner intended by the manufacturer as specified in the written instructions furnished with this product.

REPAIR OR REPLACEMENT AS PROVIDED UNDER THIS WARRANTY IS THE EXCLUSIVE REMEDY OF THE PURCHASER. ANY EXPRESS WARRANTY NOT PROVIDED IN THIS WARRANTY DOCUMENT, AND ANY REMEDY FOR BREACH OF CONTRACT THAT, BUT FOR THIS PROVISION, MIGHT ARISE BY IMPLICATION OR OPERATION OF LAW, IS HEREBY EXCLUDED AND DISCLAIMED. UNDER NO CIRCUMSTANCES SHALL WESCO BE LIABLE TO PURCHASER OR ANY OTHER PERSON FOR ANY INCIDENTAL OR CONSEQUENTIAL DAMAGES, WHETHER ARISING OUT OF BREACH OF WARRANTY, EXPRESS OR IMPLIED, A BREACH OF CONTRACT OR OTHERWISE. EXCEPT TO THE EXTENT PROHIBITED BY APPLICABLE LAW, ANY IMPLIED WARRANTY OF MERCHANTABILITY AND FITNESS FOR ANY PARTICULAR PURPOSE ARE EXPRESSLY LIMITED IN DURATION TO THE DURATION OF THIS LIMITED WARRANTY.

Some states do not allow the exclusion or limitation of incidental or consequential damages, or allow limitations on how long any implied warranty lasts, so the above limitations may not apply to you. This warranty gives you specific legal rights, and you may also have other rights which vary from state to state.