

# THINK ~~IN~~ OUTSIDE THE BOX!

WESCO® is pleased to present its new line of tilt carts. The carts have heavy-duty, molded, FDA compliant material polyethylene bins. Easy to move and dump, all models include bin, frame, handle, wheels and casters.

- Wheels: 10" x 2.75" or 12" x 3" black rubber tread tire, molded to polyolefin hub (depending on model).
- Swivel casters, polyurethane wheels.
- 1/2 and 1 cubic yard bins.
- Four grades: utility, standard, heavy-duty and forklift.
- Blue recycle 1/2 cubic yard bin available: #272577.
- Bins are easily cleaned with hose or pressure washer.
- Optional black polyethylene hinged lids: #272586 - 1/2 cu. yd. and #272587 - 1 cu. yd. (304 stainless hinge). Helps contain cargo and reduce odor.



**272575**  
Utility



**FORKLIFT POCKET**  
(Forklift models only)



**272583**  
Standard



**272577**  
Standard / Recycle

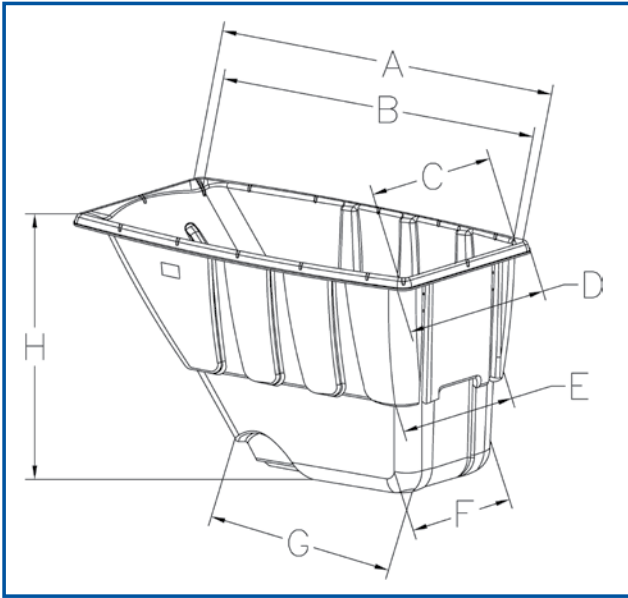

Part #	272575	272576	272577	272578	272579	272580	272581	272582	272583	272584	272585
Model #	1/2 U450B	1/2 U850B	1/2 S850BLRC	1/2 U850R	1/2 HD1400B	1/2 FL850B	1U850B	1S1250B	1S1250R	1HD2100B	1FL1250B
Type	Utility	Standard	Standard/Recycle	Standard	Heavy Duty	Fork Lift	Utility	Standard	Standard	Heavy Duty	Fork Lift
Cubic Yard	1/2	1/2	1/2	1/2	1/2	1/2	1	1	1	1	1
Capacity	450 lbs	850 lbs	850 lbs	850 lbs	1,400 lbs	850 lbs	850 lbs	1,250 lbs	1,250 lbs	2,100 lbs	1,250 lbs
Color	Black	Black	Blue	Red	Black	Black	Black	Black	Red	Black	Black
Wheel	10" x 2.75"	10" x 2.75"	10" x 2.75"	10" x 2.75"	12" x 3"	12" x 3"	10" x 2.75"	12" x 3"	12" x 3"	12" x 3"	12" x 3"
Caster	(2) 4" x 1.5"	(2) 3" x 1.25"	(2) 3" x 1.25"	(2) 3" x 1.25"	(2) 4" x 2"	(1) 4" x 2"	(2) 4" x 1.25"	(2) 4" x 1.25"	(2) 4" x 1.25"	(2) 4" x 2"	(2) 4" x 2"

DIMENSIONS

A,B	60.75", 57"	61.5", 57"	61.5", 57"	61.5", 57"	61.5", 57"	61.5", 57"	72.5", 69"	72.75", 69"	72.75", 69"	72.75", 69"	73.75", 69"
C,D	21.5", 26.5"	21.5", 26.5"	21.5", 26.5"	21.5", 26.5"	21.5", 26.5"	21.5", 27"	24.5", 29.25"	24.5", 29.25"	24.5", 29.25"	24.5", 29.25"	24.5", 29.25"
E,F	18.75", 16"	18.75", 16"	18.75", 16"	18.75", 16"	18.75", 16"	18.75", 16"	22", 19.25"	22", 19.25"	22", 19.25"	22", 19.25"	22.5", 19.25"
G,H	29", 31"	29", 31"	29", 31"	29", 31"	29", 31"	29", 31"	37", 37"	37", 37"	37", 37"	37", 37"	37", 37"
Overall Height	36.5"	36.5"	36.5"	36.5"	37.5"	37.25"	43"	43"	43"	43.25"	43.5"
Weight	51 lbs	65.5 lbs	65.5 lbs	65.5 lbs	83.5 lbs	88 lbs	74 lbs	94.5 lbs	94.5 lbs	107.5 lbs	119 lbs



1/2 and 1 Cubic Yard Lids

Lid Part #	272586	272587
Size	1/2 Cu. Yd.	1 Cu. Yd.
LA, LB, LC	24", 26.5", 28.375"	27.125", 29", 33.125"
LD, LE, LF, LG	6.5", 6.25", 7.5", 61"	6.625", 6.625", 8.25", 71.50"
Weight	11 lbs.	16.5 lbs

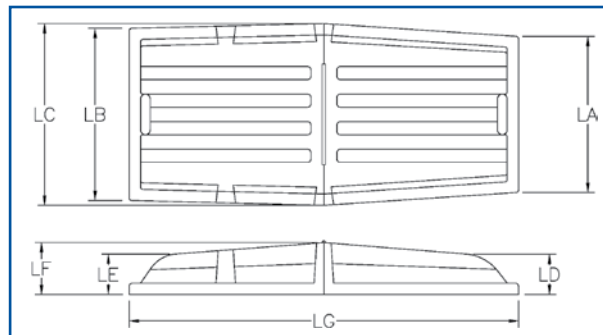

**WESCO®** Distributed by:  
Industrial Products, Inc.

1250 Welsh Rd., North Wales, PA 19454  
Phone: 215-699-7031  
Fax: 215-699-3836  
<http://www.wescoimg.com>  
<http://www.lexcoeng.com>

For more details on this equipment or for information regarding any of the products available from WESCO Industrial Products, Inc., please contact your authorized dealer.